

Marine Bronze 5kg/cm² Rising Stem Gate Valves **JIS F 7367**
Marine Bronze 10kg/cm² Rising Stem Gate Valves **JIS F 7368**

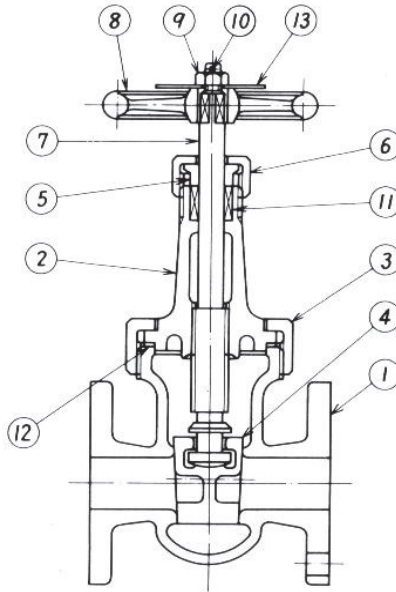

DIMENSIONS

Unit : mm

RATING	SIZE	FACE TO FACE	FLANGE			HEIGHT	HANDLE DIA	WEIGHT (kg)
			DIA	PCD	BOLT HOLE			
5kgf/cm ² (F7367)	15	90	80	60	4-12	175	80	2.29
	20	100	85	65	4-12	200	80	2.98
	25	110	95	75	4-12	220	100	4.10
	32	130	115	90	4-15	250	100	5.79
	40	140	120	95	4-15	290	125	7.78
10kgf/cm ² (F7368)	15	100	95	70	4-15	175	80	2.96
	20	110	100	75	4-15	200	80	3.89
	25	120	125	90	4-19	220	100	5.82
	32	140	135	100	4-19	250	100	7.52
	40	150	140	105	4-19	290	125	9.71

NO.	COMPONENT	MATERIAL
1	Body	Bronze
2	Bonnet	Bronze or Brass
3	Bonnet nut	Bronze or Brass
4	Disc	Bronze or Brass
5	Packing gland	Brass
6	Packing gland nut	Brass
7	Stem	Brass
8	Handwheel	Cast Iron
9	Hexagon nut	Brass
10	Split pin	Brass
11	Packing	Teflon
12	Name plate	Brass or Al

Test Pressure (kgf/cm²)

RATING	5	10
SHELL HYD' TEST	10.5	21.0
SEAT HYD' TEST	7.7	15.4

Fluid Condition & Max. Working Pressure (kgf/cm²)

FLUID CONDITION	RATING	
	5	10
STEAM	2	2
OIL AND PULSATION WATER	5	10
NON SHOCK WATER OF 120°C AND UNDER	7	14