

for Reference only

No.	DATE	ALTERATION	ENGINEER
Δ			
Δ			
Δ			

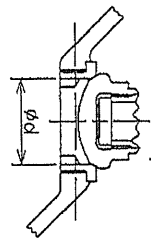

SIZE 50 & under

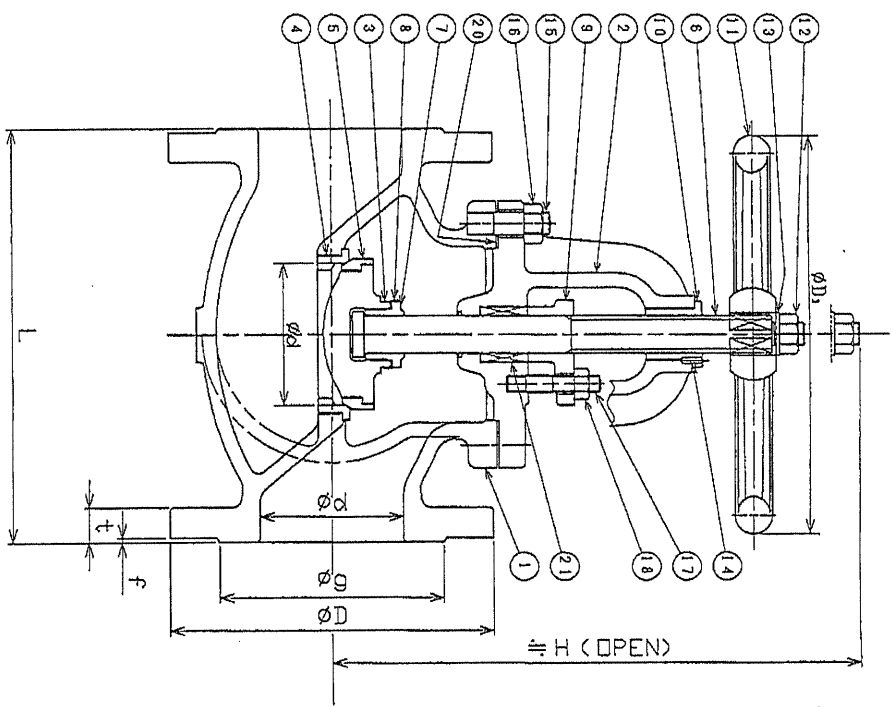
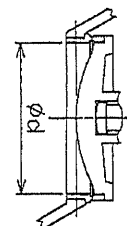

SIZE 250

SIZE	d	L	FLANGE (BS EN1092-2 PN16)						D ₁	H	O ₁ (Y)
			D	9	f	1	3	1			
50	50	203	165	-	-	99	3	20	180	255	30
65	65	218	185	-	-	118	3	20	200	289	10
80	80	241	200	-	-	132	3	22	224	329	20
100	100	292	220	-	-	156	3	24	280	387	10
125	125	330	250	-	-	184	3	26	315	398	10
150	150	356	285	-	-	211	3	26	355	457	5
200	200	495	340	-	-	266	3	30	450	581	
250	250	622	405	-	-	319	3	32	500	665	

21	Grand Packing	Non-Asbestos	1set		
20	Gasket	Non-Asbestos	1		
19					
18	Hexagon nut	Steel	2		
17	Stud bolt	Steel	2		
16	Hexagon nut	Steel	~		
15	Stud bolt	Steel	~		
14	Spring pin	Steel	1		
13	Washer	Steel	1		
12	Hexagon nut	Steel	1		
11	Hand wheel	Cast Iron	1		
10	Screw bush	Gunmetal	1	1400 LG2	
9	Gland	Cast Iron	1	EN1561 G.L-200	
8	Lock washer	Brass	1	2870 CZ105	
7	Disc hanger	Gunmetal	1	1400 LG2	
6	Stem	Brass	1	2874 CZ122	
5	Disc seat ring	Gunmetal	1	1400 LG2	
4	Body seat ring	Gunmetal	1	1400 LG2	
3	Disc seat ring	Cast Iron	1	EN1561 G.L-200	
2	Bonnet	Cast Iron	1	EN1561 G.L-200	
1	Body	Cast Iron	1	EN1561 G.L-200	

PN16-50~250
CAST IRON GLOBE VALVE
Gunmetal trim Fig. 34

THIRD ANGLE PROJECTION	TEST PRESS.	HYDROSTATIC
SHELL	2.40 MPa	
SEAT	1.78 MPa	
SCALE		

SHIMADZU VALVE CO., LTD.
SHIMADZU VALVE CO., LTD.
SOS-H-R-075